

# VORTEX

Float Valves



# VORTEX FLOAT VALVE

## PRODUCT INFO



### Description

**Vortex float valves** are float operated valves for use in automatic filling of water tanks, troughs, cisterns etc. The valve is configured for **above water mounting**. The float operates a small pilot valve which in turn operates the main diaphragm valve. Vortex float valves are a good choice where maximum **flow**, compact, robust, non corrosive construction and variable float levels are required.

### Applications

Maintaining Water Levels in:

- Water Storage Tanks
- Water Cooling Towers
- Air Conditioning Systems
- High Pressure Cleaning Systems
- Animal Drinking Troughs
- Irrigation Applications

### Mounting Positions

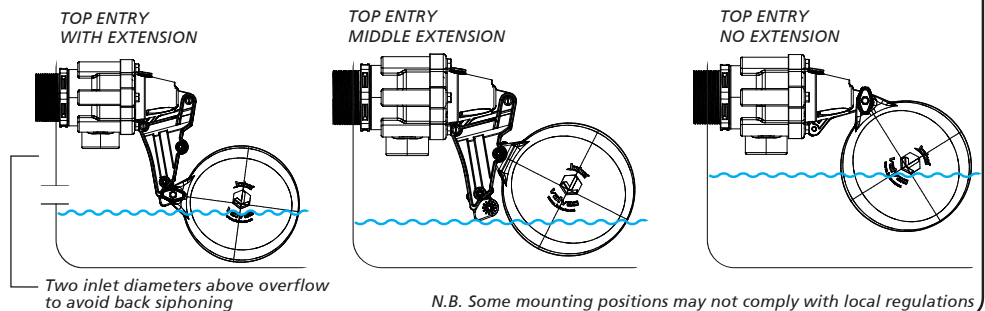

### Flow Graph ( All Sizes )

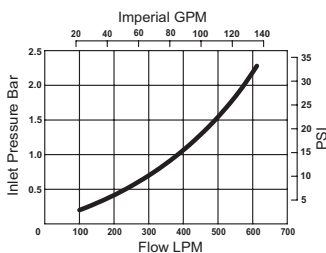

### Features

- High flow
- Compact robust construction
- Mounts horizontally or vertically
- Made from corrosion resistant materials
- Valve unscrews from tail for easy Valve seal access
- Shuts down slowly to minimise water hammer
- 20 - 60mm (¾" - 2 ½") water level differential (increases as water inlet pressure increases)
- Pressure rating 0.3 - 7 Bar (5 - 100 PSI)
- Float position easily adjustable with no tools
- Valve has switch to lock it in off position
- Has port to connect Frostpro anti freeze device

### Options

#### Inlet Size

	1 ¼"	1 ½"	2"
BSP	32mm	40mm	50mm
NPT	1 ¼"	1 ½"	2"

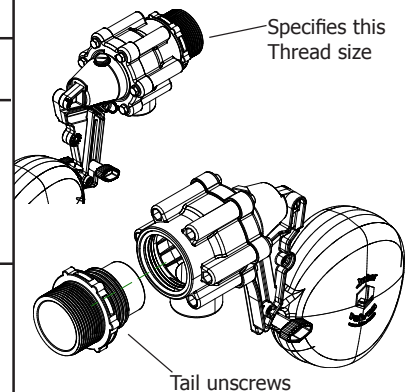

**Floats:** 70mm wide floats supplied standard.

Note: Not Suitable for underwater mounting. Refer to VXVB for Vortex underwater mounting.

Standard Float 70mm

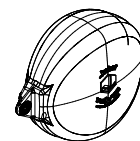

### VORTEX FLOAT VALVE SPECIFICATION

PRODUCT	CODE	INLET SIZE	CODE
Vortex Float Valve	VXV	1 ¼" bsp	32
		1 ½" bsp	40
		2" bsp	50
		1 ¼" NPT	114
		1 ½" NPT	112
		2" NPT	2

eg A Vortex Float Valve with 2" BSP thread has following spec numbers VXV50

Note: Product may differ slightly from these specs due to ongoing product development.

# VORTEX FLOAT VALVE

## DIMENSIONS & MATERIALS

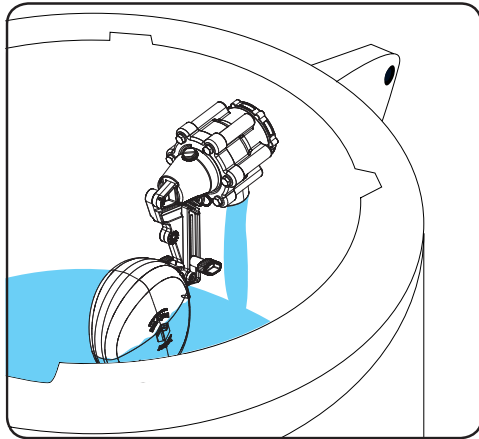

### Vortex Dimensions

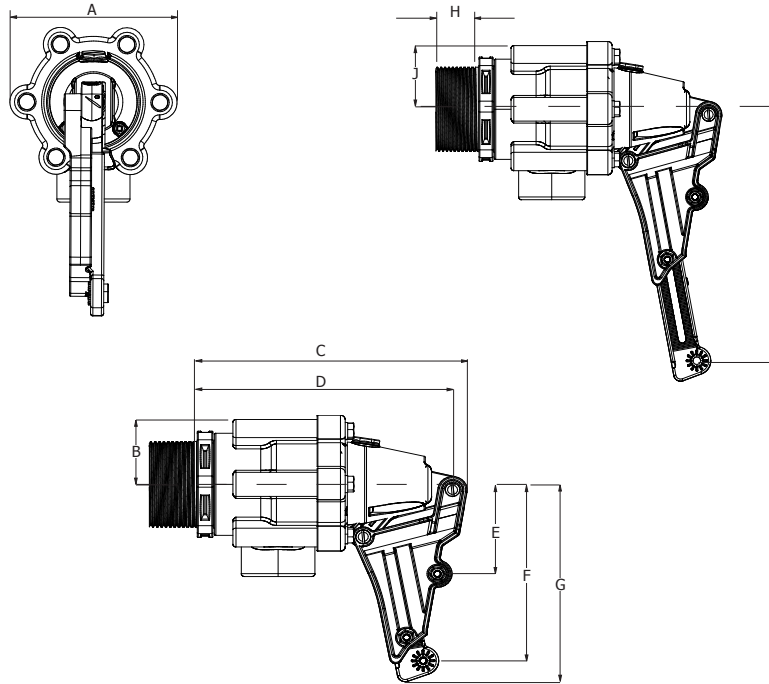

### Float Dimensions

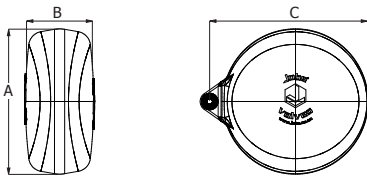

70mm Float

### Vortex Dimensions

	mm	inches
A	108	4 1/4
B	45	1 25/32
C	173	6 13/16
D	164	6 17/32
E	58	2 9/32
F	119	4 11/16
G	131	55/32
H	31	1 7/16
I	176	6 15/16

### Float Dimensions

70mm Float	mm	inches
A	70	2 3/4
B	149	5 7/8
C	162.5	6 13/32

### Materials

Valve Body	GF Nylon
White Internal, External	Acetal
Arm Assembly	ABS
Diaphragm	EPDM
Seal	Urethane
Springs, Bolts, Nuts, Pin, Screws	304 Stainless Steel
O'Rings	Nitrile
Float	HDPE

Maximum Temperature of Operation 60°C, 140°F

# VORTEX FLOAT VALVE

## PARTS IDENTIFICATION SHEET

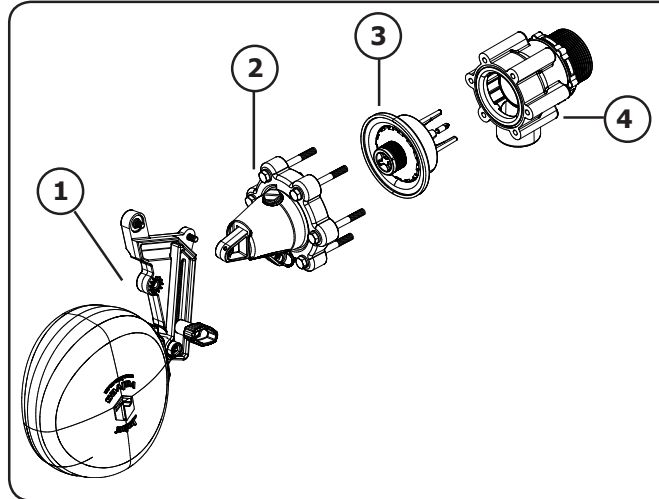
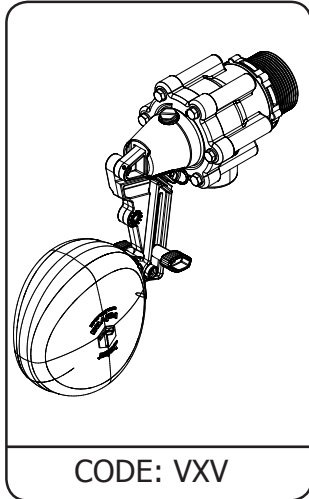

CODE	DESCRIPTION
1	VXP1 Float Assembly
2	VXP2 Cap & Actuator Assembly
3	VXP3 Diaphragm Assembly
4	Base Assembly

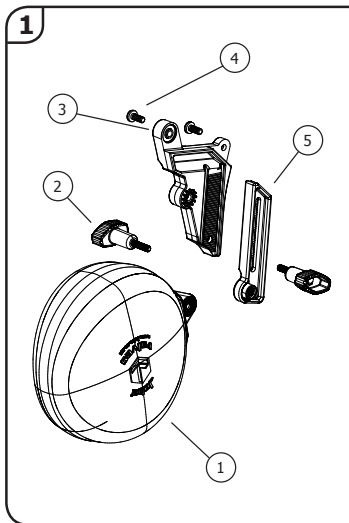

CODE	DESCRIPTION
1	VXP1010 70mm Float
2	VXP1020 Wing Bolt
3	VXP1030 Extension Arm
4	VXP1040 Bolt M5 x 12 Pan Slot
5	VXP1050 Extension Slide

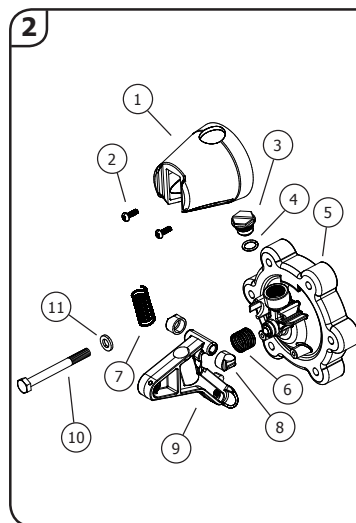

CODE	DESCRIPTION
1	VXP2010 Actuator Cap
2	VXP2020 6g x 10 S/S Screw
3	VXP2030 Frost Pro Plug
4	VXP2040 Frost Pro O'ring
5	VXP2050 Valve Cap Assembly
6	VXP2060 Damping Spring
7	VXP2070 Actuator Spring
8	VXP2080 Bearings (set of two)
9	VXP2090 Actuator Arm
10	VXP2100 Bolt M6 x 65
11	VXP2110 Washer M6 x 12.5

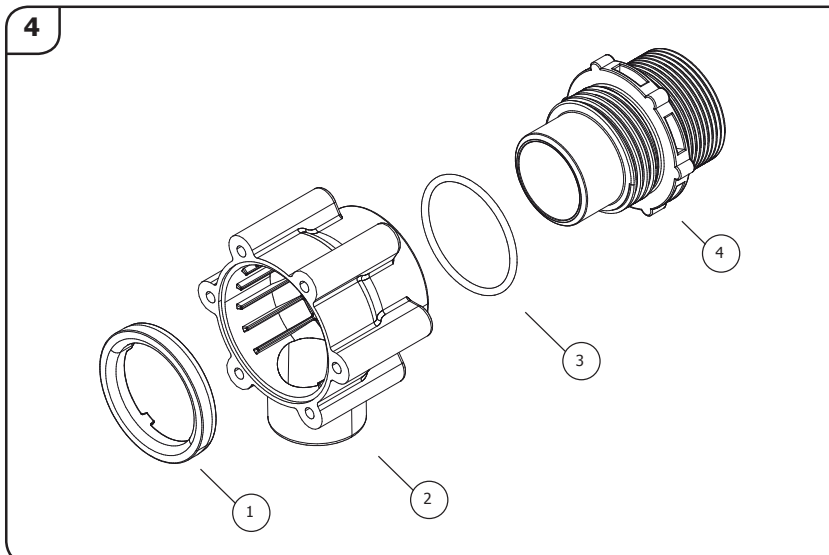

CODE	DESCRIPTION
1	VXP4010 Vortex Retainer
2	VXP4020 Vortex Base
3	VXP4030 Vortex O'ring
4	VXP4040 Vortex Tail 32mm
	VXP4045 Vortex Tail 40mm
	VXP4050 Vortex Tail 50mm
	VXP4055 Vortex Tail 1 1/4" NPT
	VXP4060 Vortex Tail 1 1/2" NPT
	VXP4065 Vortex Tail 2" NPT