

TRANZ FORMER VALVE

PRODUCT INFO



TRANZ FORMER™

Description

Tranz Former Valves are designed to fit to an existing common tank float valve that is mounted to the side wall of a tank. The Tranz Former will transform a common low flow valve into a high flow Diaphragm valve by utilizing the existing valve as the Float, mount & Actuator.

Tranz Former valves are a good choice where there is an existing valve where a higher Flow is required without drilling holes in the side wall of a tank or using expensive mountings.



Transforms a Common Valve into a Full Flow Valve

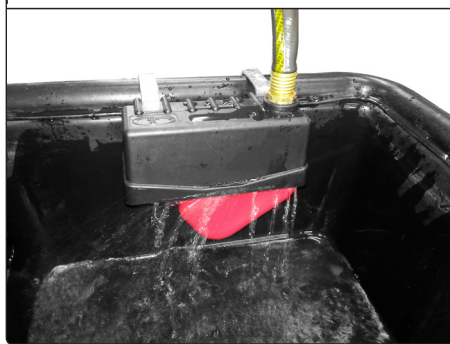

Applications

Maintaining water levels in:

- Animal drinking troughs
- Water storage tanks
- Water Cisterns

TRANZ FORMER VALVE FLOAT VALVE SPECIFICATION

PRODUCT	INLET SIZE	CODE
Tranz Former	¾" GHT	TFV

Features

- Unleashes the potential of your water supply
- Fit your hose quickly & easily without twisting the hose
- Fits most over the top clamp on float valves
- Convert your existing float in seconds
- Made tough to last
- Increase the flow into trough
- Easy to clean
- Has internal filter
- Non corrosive material construction

Flow Graph

Open Hose	Common Float	With Tranz Former
GPM	GPM	GPM
5	3	3.5
10	3.5	9.5
15	4	13
20	4	18

Flows stated in US Gallons per minute

Note: Product may differ slightly from these specs due to ongoing product development.

TRANZ FORMER VALVE

DIMENSIONS & MATERIALS



TRANZ FORMER™

Tranz Former Dimensions

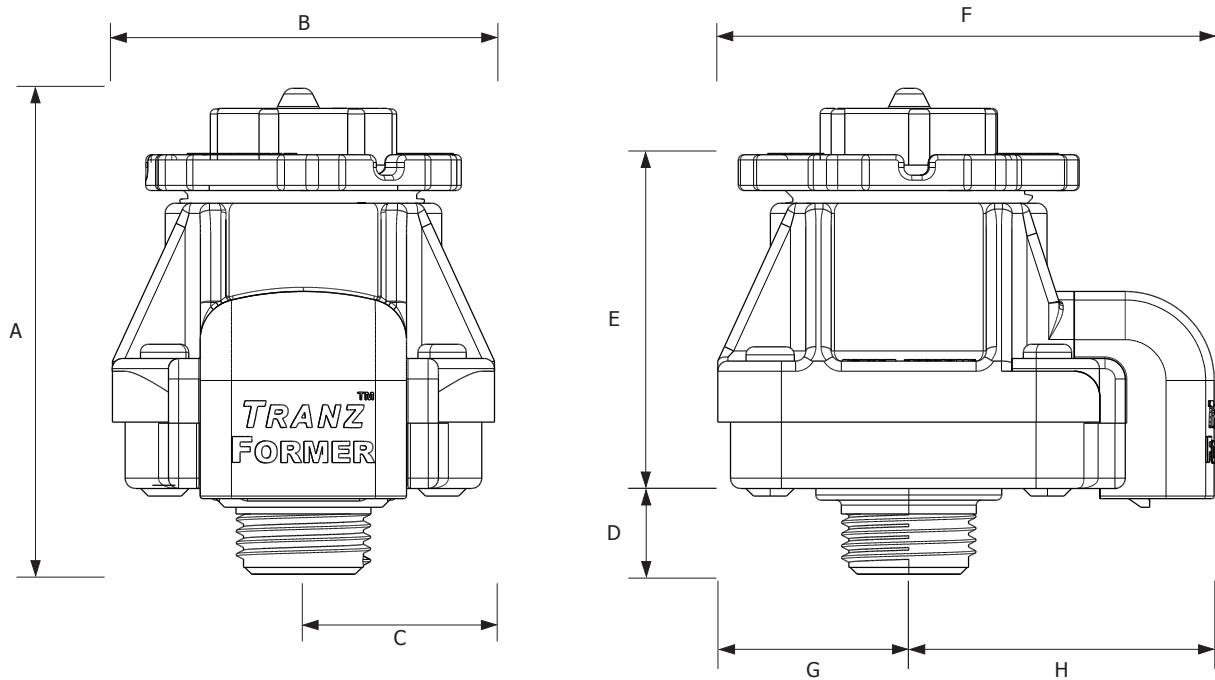

Tranz Former Dimensions

	mm	inches
A	89	3 1/2
B	75	2 15/16
C	37	1 7/16
D	17	11/16
E	63	2 1/2
F	99	3 7/8
G	37	1 7/16
H	62	2 7/16

Materials

Valve Body	Glass Filled Nylon
White Internal parts	Acetal
Diaphragm	EPDM
Seal	Urethane
O'rings & GHT Seal	Nitrile
Screws & Spring	304 Stainless Steel
Filter	PP & Nylon

Maximum Temperature of Operation
60°C, 140°F

TRANZ FORMER VALVE

PARTS IDENTIFICATION SHEET



TRANZ FORMER™

	CODE	DESCRIPTION
	1	TFP1 Locknut Assembly
	2	TFP2010 10g x 1" S/S Screw (x4)
	3	TFP2015 Spout
	4	TFP2 Square Base Assembly
	5	TFP3010 Pilot Flow Filter
	6	TFP3 Diaphragm Assembly (Includes Filter)
	7	TFP2020 Square Cap