

TOPAZ INDUSTRISTRO

PRODUCT INFO



Conforms to NSF/ANSI STD 372

TOPAZ INDUSTRISTRO

FLOAT VALVE

Description

Topaz Industro Float Valves are designed to maintain water levels in applications requiring a valve with high mechanical strength and heat resistance. Some typical applications would be refilling cooling towers and storage tanks, high pressure cleaning and car wash systems as well as many light industrial, air conditioning and irrigation installations.

Applications

Maintaining Water Levels in:

- Car Wash systems
- Water Storage Tanks
- Water Cisterns
- Air Conditioning Systems
- High Pressure Cleaning Systems
- Irrigation Applications

Flow Graph

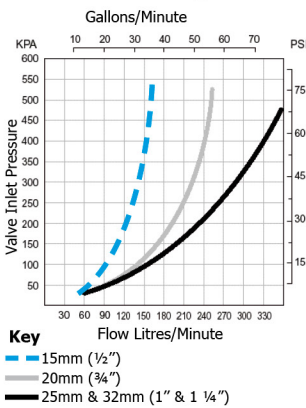

Features

- High flow
- Compact robust construction
- Maximum water temperature 80°C / 176°F
- Made from approved materials
- Mounts horizontally or vertically
- Made from corrosion resistant materials
- Shuts down slowly to minimise water hammer
- 20 - 60mm (3/4" - 2 1/2") water level differential (increases as water inlet pressure increases)
- Pressure rating 0.3 - 7 Bar (5 - 100 PSI)
- Float position easily adjustable with no tools
- Valve has switch to lock it in off position
- Has port to connect Frostpro anti freeze device

Mounting Positions

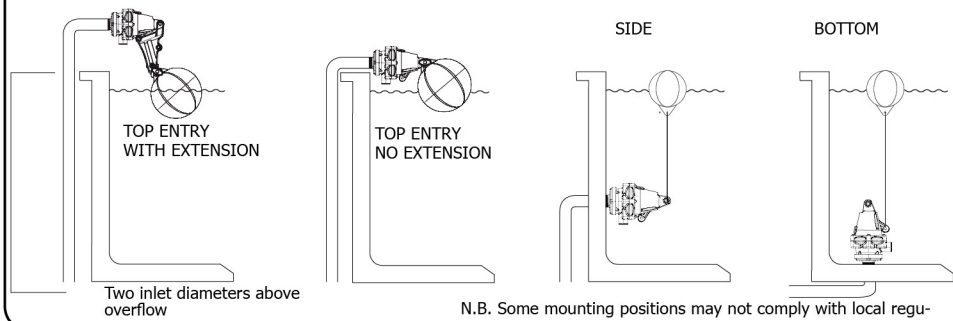

Options

	BSP			NPT			Long Tail: Supplied with backnut and seal washer.
Inlet Size	3/4"	1"	1 1/4"	3/4"	1"	1 1/4"	
Short Tail	✓	✓	✓	✓	✓	✓	
Long Tail	✓	✓	✓	✓	✓	✓	

	Detach		
	Standard	Optional	
Floats: 125mm wide floats supplied standard. Note: Suitable for any mounting position 70mm and 95mm floats optional Note: Suitable for top entry only.	 125mm	 70mm	 95mm

TOPAZ INDUSTRISTRO FLOAT VALVE SPECIFICATION

PRODUCT	CODE	INLET SIZE	CODE	OPTIONS	CODE
Topaz Industro Float Valve	TPVI	3/4" bsp/npt	20	Detach Base	D
		1" bsp	25	Long Tail Thread	LT
		1" npt	1		
		1 1/4" bsp	32	70mm wide Float	F70
		1 1/4" npt	114	95mm wide Float	F95

(e.g) A Topaz Trough Valve with: 3/4" bsp inlet thread, detach base, long tail thread has the following spec number: TPVI 20 D LT

NOTE: If no options are specified the standard ones will be supplied

Note: Product may differ slightly from these specs due to ongoing product development.

200 L / MIN

TOPAZ INDUSTRO

DIMENSIONS & MATERIALS



TOPAZ INDUSTRO

FLOAT VALVE

Topaz Dimensions

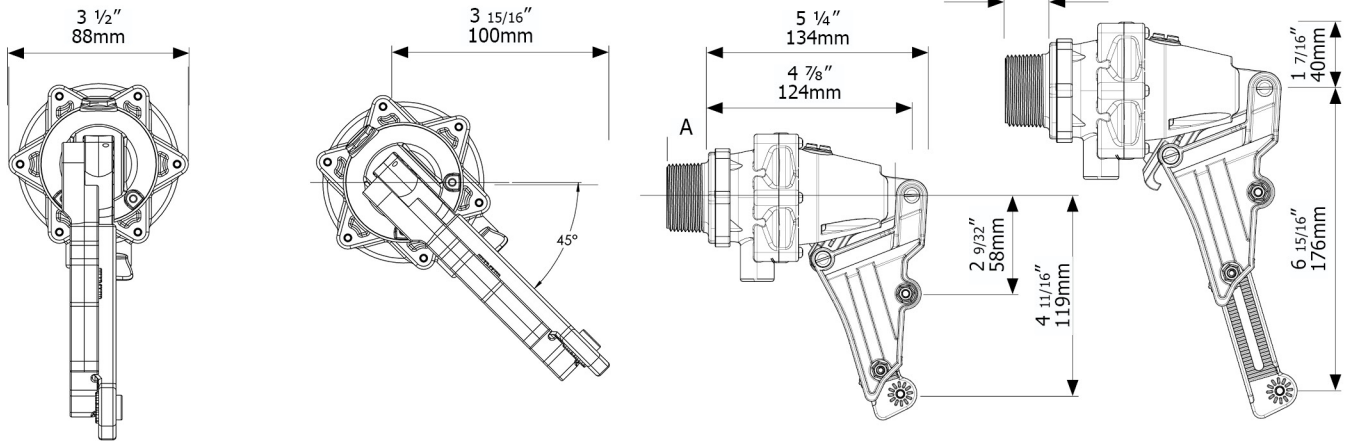

Float Dimensions

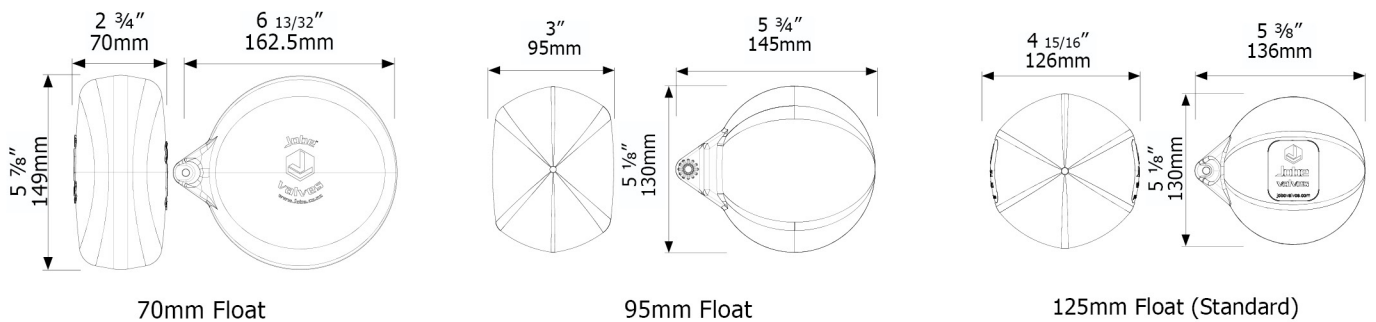

Materials

Valve Body	Grivory	Springs, Bolts, Nuts, Pin, Screws	304 Stainless Steel
White Internal Parts	TE21 Acetal	O'Rings	Nitrile
Filter	PP/Nylon	Float	HOPE
Diaphragm	EPDM	Float Cord	Polyester
Valve Seal	Santoprene		

Tail Dimensions

Dimension A	mm	inches
20mm (3/4") Short tail	22	7/8
25mm (1") bsp/npt short tail	22	7/8
32mm (1 1/4") bsp/npt short tail	25	1
15mm (1/2") long tail	100	4
20mm (3/4") long tail	38	1 1/2
25mm (1") bsp/npt long tail	54	2 1/8
32mm (1 1/4") bsp/npt long tail	60	2 3/8

Maximum Operating Temperature

80°C, 176°F

200 L / MIN

TOPAZ INDUSTRISTRO

PARTS IDENTIFICATION SHEET



TOPAZ INDUSTRISTRO

FLOAT VALVE



Conforms to NSF/ANSI STD 372

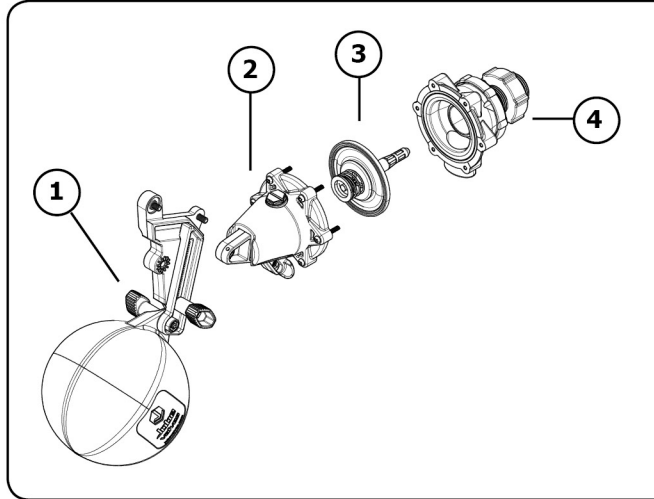
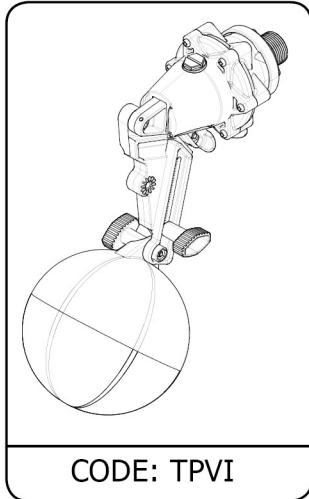

CODE	DESCRIPTION
1	TPPI1 Float Assembly
2	TPPI2 Cap & Actuator Assembly
3	TPPI3 Diaphragm Assembly
4	Detach Base Assembly

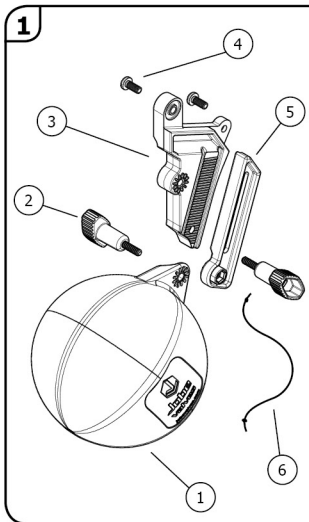

CODE	DESCRIPTION
1	TPPI10110 70mm Float
	TPPI10115 95mm Float
	TPPI10120 125mm Float
2	TPPI1020 Wing Bolt
3	TPPI1030 Extension Arm
4	TPPI1040 Bolt M5 x 12 Pan Slot
5	TPPI1050 Extension Slide
6	TPPI1060 Float Cord

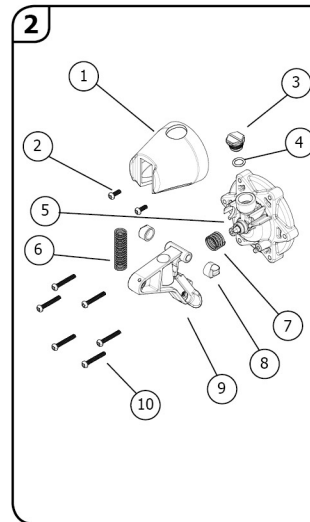

CODE	DESCRIPTION
1	TPPI2010 Actuator Cap
2	TPPI2020 6g x 10 S/S Screw
3	TPPI2030 Frost Pro Plug
4	TPPI2040 Frost Pro O'ring
5	TPPI2050 Valve Cap Assembly
6	TPPI2060 Actuator Spring
7	TPPI2070 Damping Spring
8	TPPI2080 Bearings (set of two)
9	TPPI2090 Actuator Arm
10	TPPI2100 6g x 25 S/S Screw

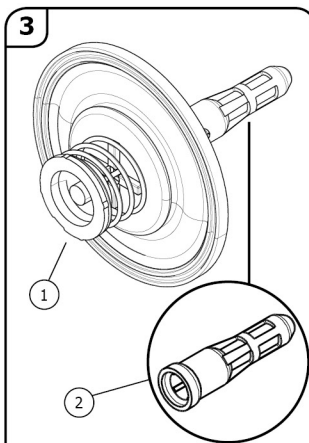

CODE	DESCRIPTION
1	TPPI3 Diaphragm Assembly
2	TPP3010 Pilot Flow Filter (Fine)
	TPP3011 Pilot Flow Filter (Coarse)

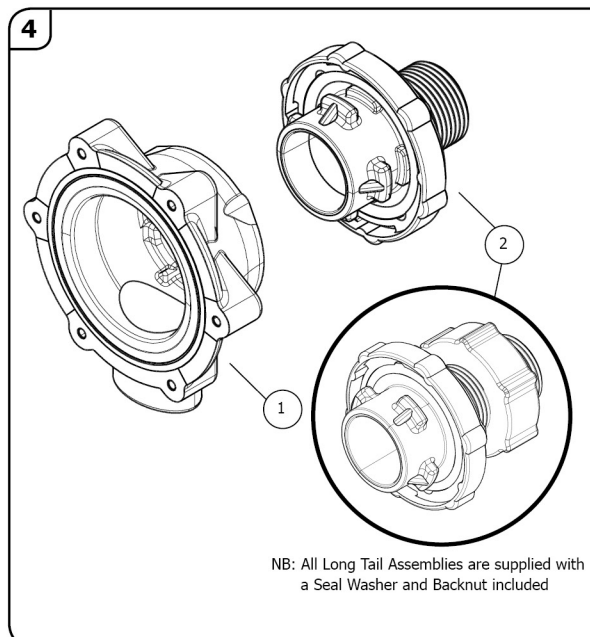

CODE	DESCRIPTION
1	DTP11 Industro Detach Base
2	BSP Tails
	Short Tail Assembly (BSP)
DTP1020	Industro Detach Tail 20mm(3/4") Short
DTP1025	Industro Detach Tail 25mm(1") Short
DTP1032	Industro Detach Tail 32mm(1 1/4") Short
	Long Tail Assembly (BSP)
DTP1015L	Industro Detach Tail 15mm (1/2") Long
DTP1020L	Industro Detach Tail 20mm (3/4") Long
DTP1025L	Industro Detach Tail 25mm (1" bsp) Long
DTP1032L	Industro Detach Tail 32mm (1 1/4" bsp) Long
	NPT Tails
	Short Tail Assembly (NPT)
DTP10075	Industro Detach Tail 3/4" npt
DTP10100	Industro Detach Tail 1" npt
DTP10125	Industro Detach Tail 1 1/4" npt
	Long Tail Assembly (NPT)
DTP10050L	Industro Detach Tail 1/2" npt Long
DTP10075L	Industro Detach Tail 3/4" npt Long
DTP10100L	Industro Detach Tail 1" npt Long
DTP10125L	Industro Detach Tail 1 1/4" npt Long

200 L / MIN