

20 L / MIN



FLOAT VALVE



ROJO FLOAT VALVE

DIMENSIONS & MATERIALS



20 L / MIN

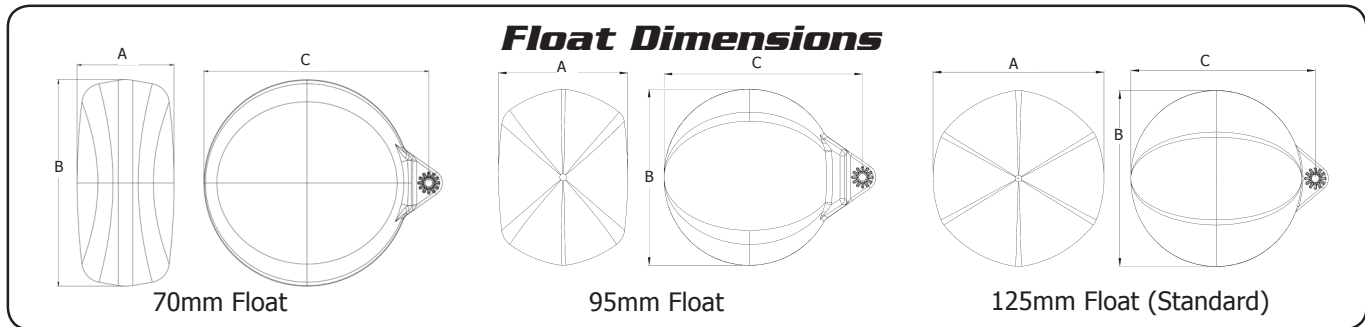
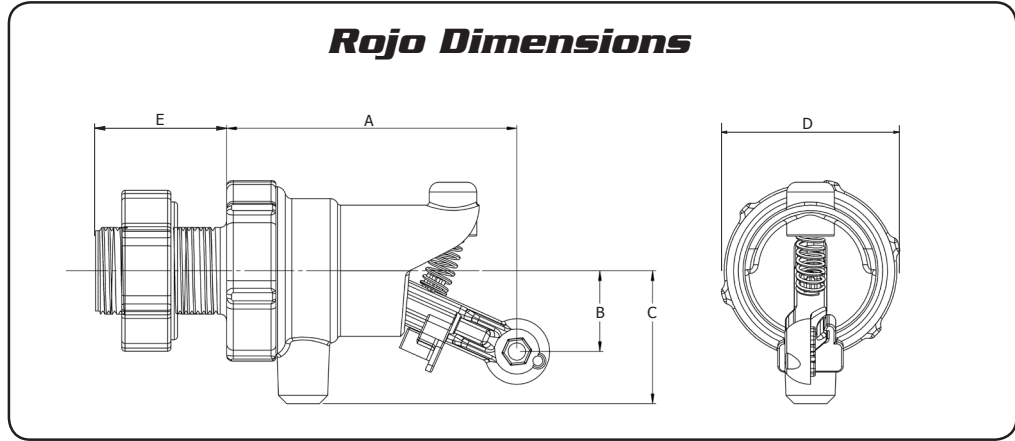
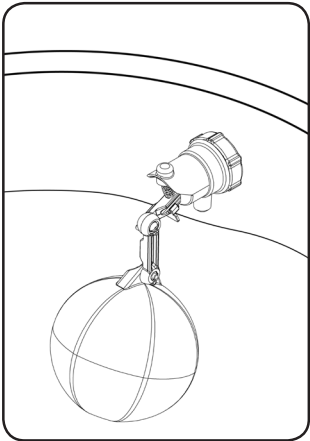

Note: 70mm & 95mm floats are suitable for top entry only.

Rojo Dimensions								
			mm			inches		
A			88			3 1/2		
B			25			1		
C			40			1 9/16		
D			56			2 1/4		
E			38			1 1/2		
Float Dimensions								
70mm Float			95mm Float			125mm Float		
	mm	inches		mm	inches		mm	inches
A	70	2 3/4	A	95	3 3/4	A	126	4 15/16
B	149	5 7/8	B	130	5 1/8	B	130	5 1/8
C	162.5	6 13/32	C	145	5 3/4	C	136	5 3/8

Materials	
Valve Body Tail & Nut	ABS Glass Filled Nylon
Arm Extension Arms Internal Black Mouldings	Glass Filled Nylon
Yellow Valve Parts Filter	Acetal
Float	HDPE
Seal Washer	LDPE
Springs Bolts Nuts	304 Stainless Steel
O' Rings	Nitrile
Float Cord	Polyester

Maximum Temperature of Operation 60°C, 140°F

ROJO FLOAT VALVE

PARTS IDENTIFICATION SHEET



20 L / MIN

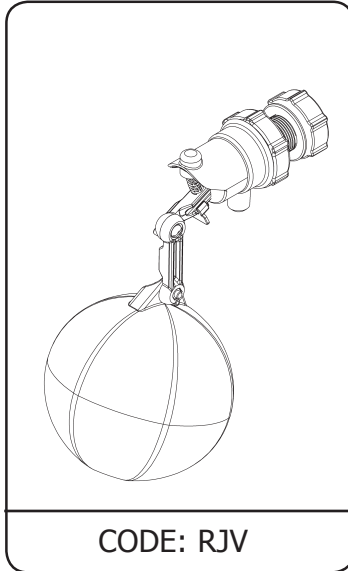

CODE	DESCRIPTION
1	Float & Connection
2	Body Assembly
3	RJP3A Inner Cartridge Assembly
RJP3B	Inner Cartridge Assembly High Flow (L/P)
4	RJP415 15mm (1/2") Tail Assembly
RJP420	20mm (3/4") Tail Assembly
RJP420E	20mm (3/4") Ezi Start Tail Assembly

CODE	DESCRIPTION
1	RJP1010 70mm Float
RJP1011	95mm Float
RJP1012	125mm Float
2	RJP1020A Arm Bolt Slot
RJP1020B	Arm Bolt Phillips
3	RJP1030 Extension Arm 25mm
RJP1031	Extension Arm 50mm
RJP1032	Extension Arm 75mm
RJP1033	Extension Arm 100mm
4	RJP1040 Float Cord

CODE	DESCRIPTION
1	RJP2010 Lock-Off Switch
2	RJP2020 Arm Spring
3	RJP2030 Body
4	RJP2040 Arm Assembly
5	RJP2050 Retainer

CODE	DESCRIPTION
1	RJP3010 Inner Cartridge Std
RJP3011	Inner Cartridge High Flow (LP)
2	RJP3020 Filter

CODE	DESCRIPTION
1	RJP4010 15mm (1/2") Tail
RJP4011	20mm (3/4") Tail
RJP4012	20mm (3/4") Tail Ezi Start
2	RJP4020 15mm Seal Washer
RJP4021	20mm Seal Washer
RJP4030	15mm (1/2") Backing Nut
3	RJP4131 20mm (3/4") Backing Nut

ROJO FLOAT VALVE

PRODUCT INFO



Description

Rojo Float Valves are float operated valves for automatic filling of water storage vessels. The Rojo can be **mounted above or below water level**. It is a simple mechanically operated valve. The Rojo is a good choice where its **low flow** is sufficient and its compact non corrosive construction is beneficial.

Applications

Maintaining water levels in:

- Animal drinking troughs
- Water storage tanks
- Water Cisterns
- Process applications

Flow Graph

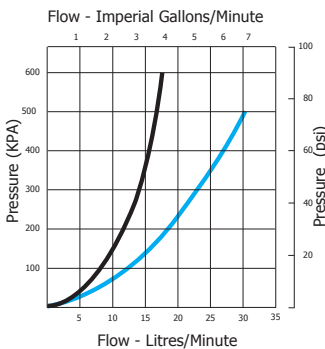

Key
 ■ Standard
 ■ Low Pressure

Features

- Side, Bottom, Top Mounting
- Valve body screws apart by hand for easy servicing
- Flow stops when unscrewed for servicing
- Supplied with backnut and seal washer
- Built in check valve
- Fully adjustable float angle
- Pressure range 0-10 Bar (0-150 PSI)
- Low pressure model also available 0-5 Bar(0-75 psi) gives 60% more flow
- Non corrosive material construction
- Has switch to lock valve in off position

Mounting Positions

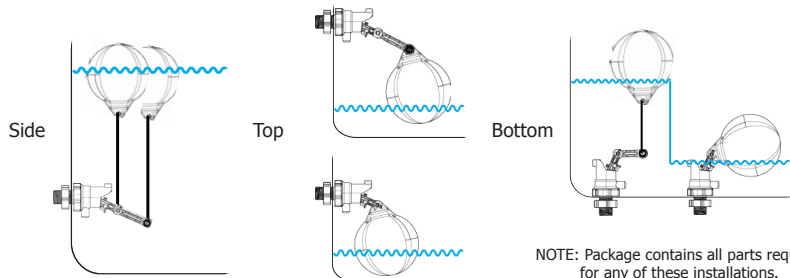

NOTE: Package contains all parts required for any of these installations.

Options

Inlet sizes: 15mm 1/2" bsp/npt
 20mm 3/4" bsp/npt
 3/4" 3/4" npt

Pressure Rating:
STD 0 Bar(0 PSI) - 10 Bar (150 PSI)
HF 0 Bar(0 PSI) - 5 Bar (75 PSI)

Extension Arms:
 75mm Extension Arm supplied STD

Available Extension Arm Lengths:
 25mm 50mm 75mm 100mm

Floats: 125mm wide floats supplied standard.
 Note: Suitable for any mounting position

70mm and 95mm floats optional
 Note: Suitable for top entry only.

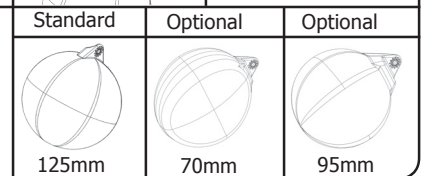
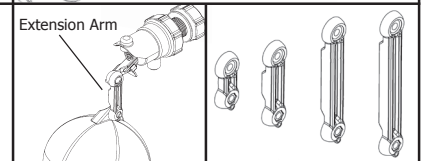
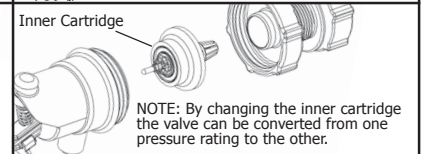
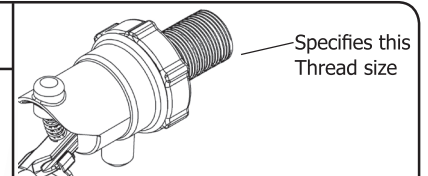

ROJO FLOAT VALVE SPECIFICATION

PRODUCT	CODE	INLET SIZE	CODE	OPTIONS	CODE
Rojo Float valve	RJV	1/2" bsp/npt	15	Low pressure	HF
			20	25mm Extn Arm	A25
		50mm Extn Arm		A50	
		75mm Extn Arm		A75	
		3/4" bsp/npt	100mm Extn Arm	A100	
70mm wide Float	F70				
				95mm wide Float	F95

(e.g) A Rojo Float Valve with: 3/4" bsp inlet, 100mm Extn Arm, 95mm Float has the following spec number: **RJV 20 A100 F95** NOTE: If no options are specified the standard ones will be supplied

Note: Product may differ slightly from these specs due to ongoing product development.

20 L / MIN